

GreenWall Multi 70 and 90

Product

GreenWall is Milford’s own quality trellis system series made of stainless steel.

The spacers in the Multi collection are designed for easy installation of the wires. The wires don’t have to be pulled through all the spacers, but can simply be fastened on the end spacers and then pushed into position and fastened on the rest. This will save time and ensures a very robust wire assembly.

Areas of use

The size of the wall bracket is chosen based on the trellis system’s size as well as the plant species and type.

GreenWall Multi 90 is our most solid spacer, designed to carry the weight of the tallest and heaviest climbing plants which also require the most space for their stems. If you can settle for a little less, er **GreenWall Multi 70** is a really good and flexible solution.

Description

GreenWall Multi 70 (GWM50/70/S) and GreenWall Multi 90 (GWM80/90/S)

- Stainless steel wall bracket for universal attachment.
- The system is installed with a maximum of 3 meters between each wall bracket.

GreenWall wire tensioners (GW/WT4/M6X55)

- Stainless steel wire tensioners for 4 mm wire.
- 240.4** Stainless steel wire Ø4 mm.
- Wire is sold in rolls of 25, 50 and 100 meters.

Installed according to Milford’s instructions.

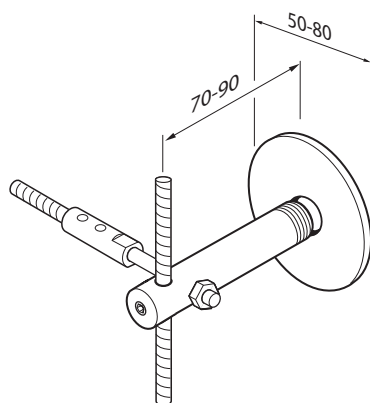

GreenWall Multi 70

GreenWall Multi 90

Liveable cities



Code	Description	Material	Distance from wall	Base plate diameter	weight/gr
GWM50/70/S	Wall bracket with fixing	Stainless steel	70 mm	50 mm	149
GWM80/90/S	Wall bracket with fixing	Stainless steel	90 mm	80 mm	417
GW/WT4/M6X55	Wire tensioner, 4 mm wire	Stainless steel			46
240.4	4 mm dia. wire (25, 50 or 100 m)	Stainless steel			37 gr/m
GWM/TE/45	Top Extender	Stainless steel			67